



## Terwa Alligator Mechanical Couplers





# Contents

<b>Introduction</b>	<b>2</b>
<b>ALC Alligator Splicing Couplers</b>	<b>3</b>
<b>ALC Installation</b>	<b>4</b>
<b>ALC-AP Headed Anchor Alligator Coupler</b>	<b>5</b>
<b>ALC-AP Installation</b>	<b>6</b>
<b>ALC-VK Transition Alligator Couplers</b>	<b>7</b>
<b>ALC-VK Installation</b>	<b>8</b>
<b>ALC-SKF &amp; ALC-SKM Continuity Alligator Couplers</b>	<b>9</b>
<b>ALC-SKF Installation</b>	<b>10</b>
<b>ALC-SKM Installation</b>	<b>11</b>
<b>Repairing Damaged or Corroded Reinforcement</b>	<b>12</b>
<b>Tools for use with Alligator Couplers</b>	<b>13</b>

## Accreditations

DIBT Approval No. Z-1.5-213

KOMO Certificate No. K21098/10

CARES Technical Approval Certificate No. 5065



Deutsches  
Institut  
für  
Bautechnik

DIBt



# Introduction

The Alligator Coupler is a splicing coupler designed to meet the requirements of BS8110 and EC2 for mechanical couplers used to form butt joints in reinforcement steel. They are supplied in a range of sizes to suit the reinforcement steel range 10mm to 40mm inclusive. The system is ideally suited to minimising steel congestion in heavily reinforced structures, providing simple connections for prefabricated reinforcement steel and facilitating the removal and replacement of damaged reinforcement steel in repair contracts.

The mechanical connection is made by inserting the rebar into each end of the coupler and tightening the lock shear bolts by hand, once satisfied that the joint is suitably assembled and aligned, the lock shear bolts are tightened up with suitable impact driver. The bolt heads shear off at the desired torque setting, giving a clear indication that installation is complete and satisfactory.



## Advantages of Alligator Mechanical Couplers

- ✓ Reduced steel congestion at joints.
- ✓ Compatible with smooth round and ribbed reinforcement steel
- ✓ Accommodates any variations in the nominal diameter of the bars being joined
- ✓ No rotation of the reinforcement steel required
- ✓ Tapered profile makes bar insertion easier
- ✓ No welded parts or joints used in the manufacturing process.
- ✓ No threading of the rebar required.
- ✓ No additional bar preparation required.
- ✓ Works with conventionally cropped reinforcement steel.
- ✓ No specialist training or skills required.
- ✓ Provides the characteristics of a continuous length of reinforcement steel.
- ✓ Gives a clear indication of correct installation.
- ✓ Available from stock in the range 10mm to 40mm diameter.
- ✓ Meets the requirements of BS8110-pt1:1997 and EC2 for mechanical connections in reinforcement steel.
- ✓ Backed up by CARES Technical Approval TA1-B 5065, up to 32mm.

## Applications

- Construction of columns with continuous reinforcement.
- Reducing steel congestion at laps in heavily reinforced structures.
- Extensions to existing structures.
- Providing a means of extension to new structures.
- Repair and replacement of damaged reinforcement steel.
- Connections between in-situ piles and pile caps.
- Connections in pre-fabricated reinforcement cages.
- Connecting precast elements.
- Closing temporary openings in structures.
- Underpinning and foundation repairs.



# Alligator Splicing Couplers

The standard product within the range, comprises of the tapered alligator profile combined with the ingenious lock shear bolts to provide a slip free joint in the reinforcement steel without relying on additional welded components to increase the bond strength. The taper profile Alligator Coupler acts as a wedge to grip the reinforcement steel maximising the surface contact between the coupler body and the reinforcement steel to achieve the slip requirements set out in BS8110-pt1:1997. The performance of the product is verified by CARES Technical Approval TA1-B 5065.

Product Code	Bar Dia. (mm)	No. of Bolts	Bolt Thread	L (mm)	d (mm)	d1 (mm)	H (mm)	h (mm)	SW (mm)	Torque Bolts (Nm)
ALC10	10	6	M12	160	35	33	48	36	13	100-115
ALC12	12	6	M12	180	35	33	51	40	13	100-115
ALC14	14	8	M12	230	40	36	56	44	13	100-115
ALC16	16	8	M12	230	40	36	56	45	13	100-115
ALC18	18	10	M12	280	44	42	60	49	13	100-115
ALC20	20	10	M16	260	47	44	75	54	17	195-215
ALC22	22	10	M16	330	53	50	68	48	17	195-215
ALC25	25	12	M16	390	56	52	75	63	17	195-215
ALC28	28	12	M20	420	66	62	88	75	22	355-405
ALC32	32	14	M20	480	73	68	91	78	22	355-405
ALC36	36	16	M20	540	79	73	99	85	22	355-405
ALC40	40	18	M20	580	79	73	105	87	22	355-405

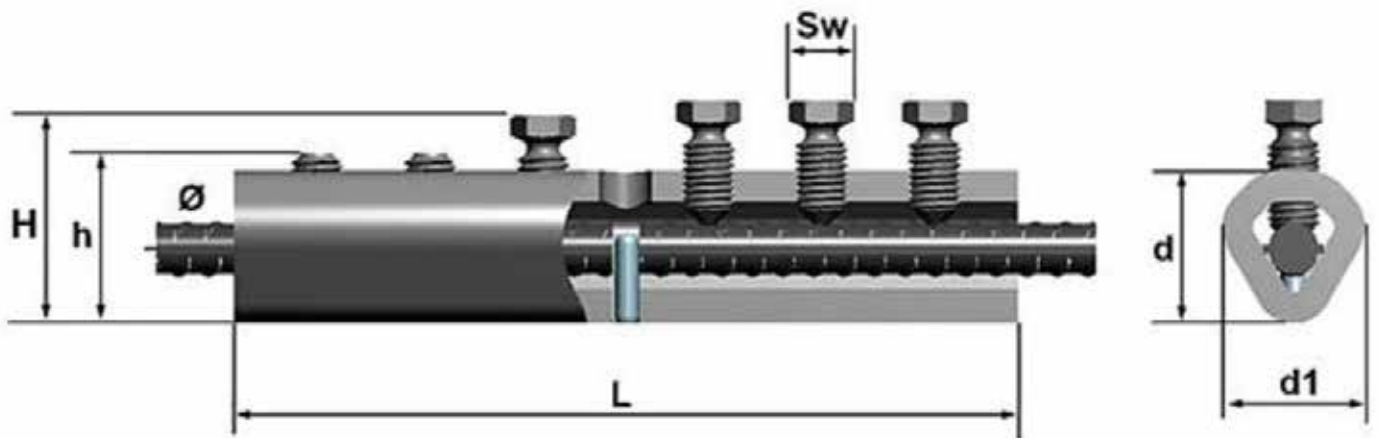



# Installation



Slide the Alligator Coupler on to the end of the first piece of reinforcement steel to be joined. The central stop pin should make contact with the end of the bar to verify the correct insertion length. There is also a viewing hole in the coupler body enabling a visual check of the insertion length. Once satisfied of the insertion length and the orientation of the coupler, tighten the lock shear bolts by hand to stabilise the coupler on the bar. Note: When replacing damaged reinforcement, the central stop pin can be removed from the coupler with a hammer and a steel punch, this allows the entire coupler to slide over the bar when splicing in replacement steel.



Insert the second piece of reinforcement steel into the opposite end of the Alligator Coupler, ensuring that it makes contact with the central stop pin. Once the second bar is fully inserted the lock shear bolts can be tightened by hand. Check the alignment of the coupler prior to the next stage.

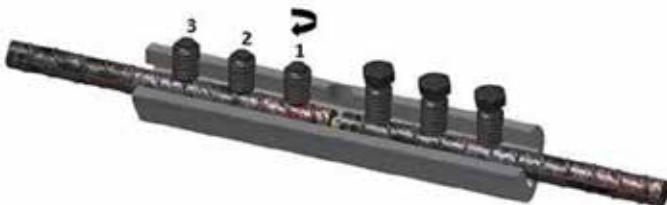

After confirming that the coupler is correctly aligned use the impact wrench (see page 13) to tighten the lock shear bolts, the bolts should be tightened on one side of the coupler first working from the central stop pin towards the outside edge of the coupler. When each bolt reaches the correct torque setting the head of the lock shear bolt will shear off. Complete this process for both sides of the coupler and all couplers at the joint.



The completed coupling will have all the bolt heads sheared off \*, providing a visual indication of correct installation.

\* In instances where the bolt head has not sheared off, normally when fixing with hand tools in confined spaces. To confirm correct installation the torque setting on the bolt should be verified with a suitably calibrated torque wrench.

# Headed Anchor Alligator Couplers

The Headed Anchor is designed to provide end anchorage and reduce reinforcement congestion. Utilising the same tapered profile and lock shear bolts as the standard coupler combined with a large back plate to facilitate load transfer into the surrounding concrete, this method of providing end anchorage reduces the congestion of steel in the anchorage zone over more

conventional reinforcement practices. Traditional construction methods generally rely on hooked or L shaped bars for end anchorage, resulting in areas of heavily congested steel, increases in required bond length and larger concrete dimensions to accommodate the minimum bending diameters on heavier bars.

Product Code	Bar Dia. (mm)	No. of Bolts	Bolt Thread	L (mm)	a (mm)	b (mm)	d (mm)	d1 (mm)	H (mm)	h (mm)	SW (mm)	Torque Bolts (Nm)
ALC-AP10	10	3	M12	88	80	8	35	33	48	36	13	90-99
ALC-AP12	12	3	M12	98	80	8	35	33	51	40	13	90-99
ALC-AP14	14	4	M12	123	100	8	37	36	56	44	13	90-99
ALC-AP16	16	4	M12	123	100	8	40	36	57	45	13	90-99
ALC-AP18	18	5	M16	150	100	10	44	42	60	49	13	90-99
ALC-AP20	20	5	M16	140	100	10	47	44	75	54	17	175-192
ALC-AP22	22	5	M16	175	100	10	53	50	68	48	17	175-192
ALC-AP25	25	6	M16	205	100	10	56	52	75	63	17	175-192
ALC-AP28	28	6	M20	225	150	15	66	62	88	75	22	355-405
ALC-AP32	32	7	M20	255	150	15	73	68	91	78	22	355-405
ALC-AP36	36	8	M20	285	150	15	79	73	99	85	22	355-405
ALC-AP40	40	9	M20	305	150	15	79	73	105	87	22	355-405

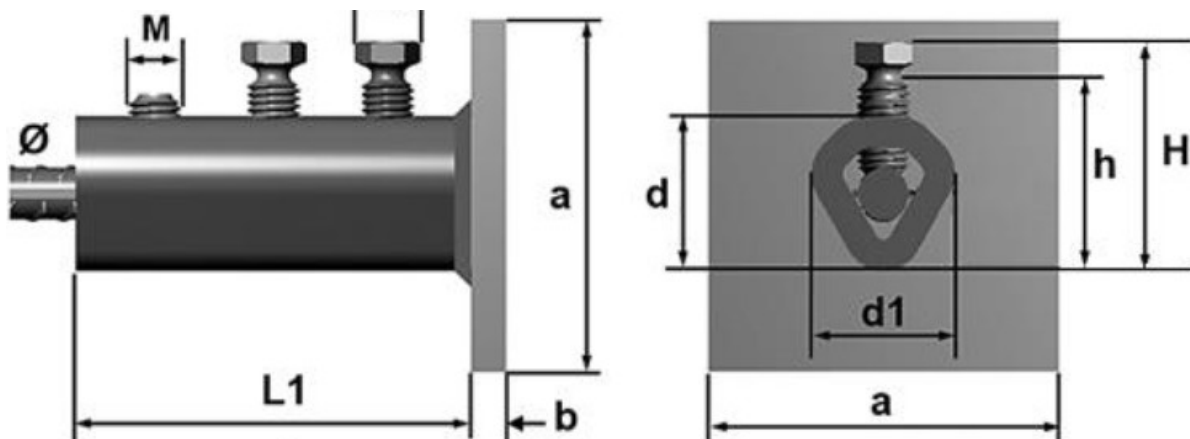

## Increases in cross sectional area and reductions in steel weight using the ALC-AP

Bar Dia. (mm)	Cross Sectional Area of Standard Hook (mm <sup>2</sup> )	Cross Sectional Area of ALC-AP Plate (mm <sup>2</sup> )	Increase in Cross Sectional Area	Weight of Rebar in 50d Splice or Bond Length (kg)	Weight of Steel in ALC-AP Plate (kg)	Reduction in Weight of Steel
10	558	6400	1147%	0.3	0.4	-
12	802	6400	798%	0.5	0.4	25%
16	1426	10000	701%	1.3	0.6	53%
20	3428	10000	292%	2.5	0.8	68%
25	5357	10000	187%	4.8	0.8	83%
32	8776	22500	256%	10.1	2.6	74%
40	13714	22500	164%	19.7	2.6	87%

# Installation

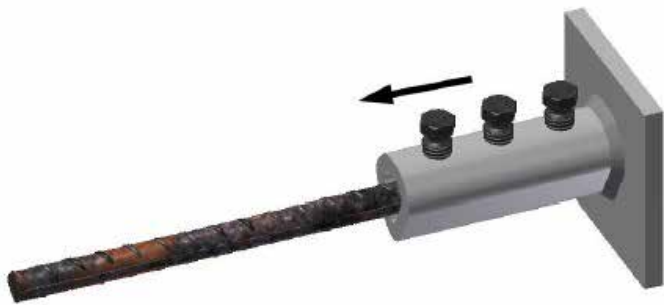

Slide the Headed Anchor Alligator Coupler over the end of the reinforcement steel that requires the anchorage until it comes to rest, ensuring the rebar has made full contact with the back plate. The lock shear bolts should be tightened by hand to stabilise the coupler.



After confirming that the coupler is correctly aligned use the impact wrench (see page 13) to tighten the lock shear bolts, the bolts should be tightened working from the back plate working towards the outside edge of the coupler. When each bolt reaches the correct torque setting the head of the lock shear bolt will shear off. Complete this process for all couplers at the joint.



# Transition Alligator Couplers

The Transition Alligator Coupler is a convenient method to increase or reduce bar diameters when design requirements call for or permit doing so. This can lead to significant reductions in steel volume and potentially reduction in element dimensions leading to reductions in steel congestion and material savings.

Product Code	Bar Dia. (mm)	No. of Bolts	Bolt Thread	L (mm)	L1 (mm)	L2 (mm)	d1 (mm)	d2 (mm35)	Sw1 (mm)	Sw2 (mm)	Torque Bolts (Nm)
ALC-VK16/10-12	16/10-12	4/3	M12/M12	205	115	90	40	35	13	13	115/115
ALC-VK20/12	20/12	3/3	M16/M12	178	88	90	47	35	17	13	215/115
ALC-VK20/14	20/14	4/4	M16/M12	227	112	115	47	37	17	13	215/115
ALC-VK20/16	20/16	4/4	M16/M12	227	112	115	47	40	17	13	215/115
ALC-VK25/16	25/16	3/4	M16/M12	221	106	115	56	40	17	13	215/115
ALC-VK25/20	25/20	5/5	M16/M12	302	166	136	56	47	17	17	215/115
ALC-VK32/20	32/20	4/5	M20/M16	282	140	136	73	47	22	17	405/215
ALC-VK32/25	32/25	7/6	M20/M16	426	238	188	73	56	22	17	405/215
ALC-VK32/28	32/28	7/6	M20/M20	446	238	208	73	66	22	22	405/215
ALC-VK40/32	40/32	7/7	M20/M20	460	230	230	79	73	22	22	405/215

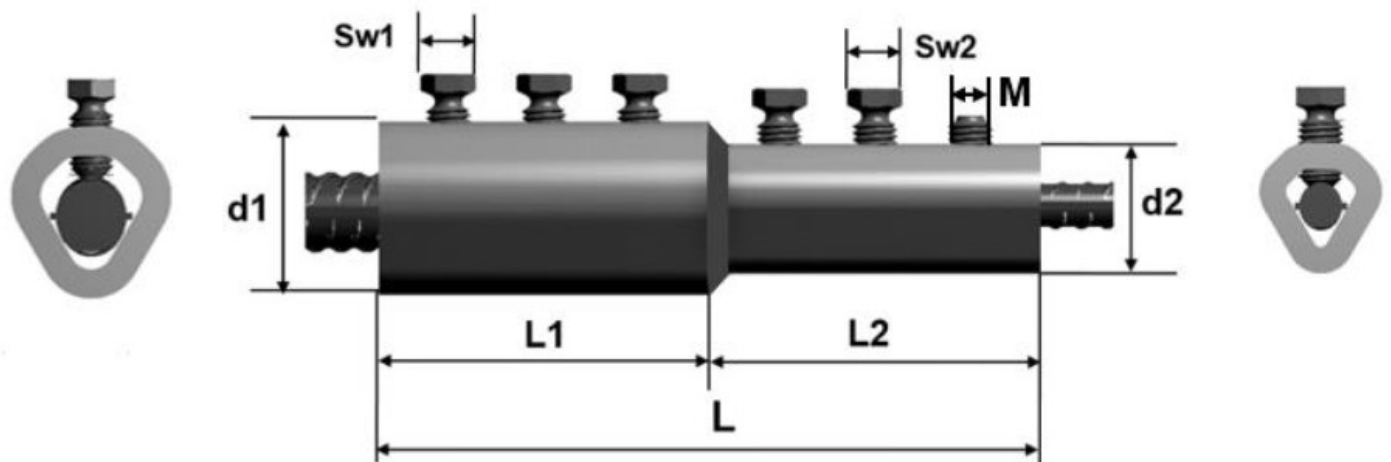



# Installation

The Coupler is installed in the same manner as the standard Alligator Coupler, but considerations for slip requirements should be measured against the expectations of the smaller diameter bar.



Slide the Alligator Coupler on to the end of the first piece of reinforcement steel to be joined. It is advisable to place the coupler over the largest bar first. By default this ensures that the correct bar is inserted into the correct side of the coupler and as the larger bar cannot pass beyond the welded section it allows a visible inspection from the open end to confirm the full insertion length has been achieved. Once satisfied of the insertion length and the orientation of the coupler, tighten the lock shear bolts by hand to stabilise the coupler on the bar.



Insert the smaller diameter reinforcement steel into the opposite end of the Transition Alligator Coupler, ensuring that it makes contact with the end of the larger diameter bar. Once the second bar is fully inserted the lock shear bolts can be tightened by hand. Check the alignment of the coupler prior to the next stage.



After confirming that the coupler is correctly aligned use the impact wrench (see page 13) to tighten the lock shear bolts, the bolts should be tightened on one side of the coupler first working from the welded joint towards the outside edge of the coupler.



When each bolt reaches the correct torque setting the head of the lock shear bolt will shear off. Complete this process for both sides of the coupler and all couplers at the joint.

\*In instances where the bolt head has not sheared off, normally when fixing with hand tools in confined spaces. To confirm correct installation the torque setting on the bolt should be verified with a suitably calibrated torque wrench.

# Continuity Alligator Couplers

The Continuity Alligator Coupler provides continuation of reinforcement through stop ends and construction joints required in the production process. It is supplied in two distinct parts the Continuity Alligator Coupler Female and the Continuity Alligator Male. This provides two methods of continuing reinforcement through the joint. The female section is always fixed to the shutter or stop end with a threaded fixing plate. After the shutter or stop end is removed there are two options:

## Option A

Where no rotation of the continuity steel is possible the Continuity Alligator Coupler Male is threaded into the threaded section of the female coupler and locked into position. The continuity steel is fixed in the same manner as the standard coupler.

## Option B

Where the continuity steel can be rotated the TSE threaded male coupler can be used to provide the continuity steel.

### Continuity Alligator Coupler - Female

Product Code	Bar Dia. (mm)	No. of Bolts	Bolt Thread	L (mm)	d (mm)	d1 (mm)	Coupler Thread	Sw (mm)	Torque Bolts (Nm)
ALC-SKF12	12	3	M12	112	40	35	M16	13	100-115
ALC-SKF16	16	4	M12	156	47	35	M20	13	100-115
ALC-SKF20	20	5	M16	188	47	37	M24	17	195-215
ALC-SKF25	25	6	M16	255	47	40	M30	17	195-215
ALC-SKF32	32	7	M20	324	56	40	M42	22	355-405
ALC-SKF40	40	9	M20	286	56	47	M48	22	355-405

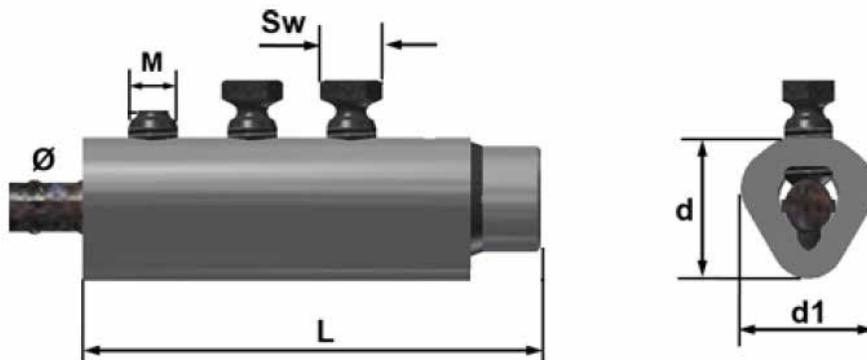

### Continuity Alligator Coupler - Male

Product Code	Bar Dia. (mm)	Bolt Thread	a (mm)	c1 (mm)	c2 (mm)	b (mm)
ALC-SKM12	12	M16	80	24	30	13
ALC-SKM16	16	M20	115	37	46	16
ALC-SKM20	20	M24	140	47	55	19
ALC-SKM25	25	M30	170	56	66	24
ALC-SKM32	32	M42	250	84	98	34
ALC-SKM40	40	M48	260	86	98	38

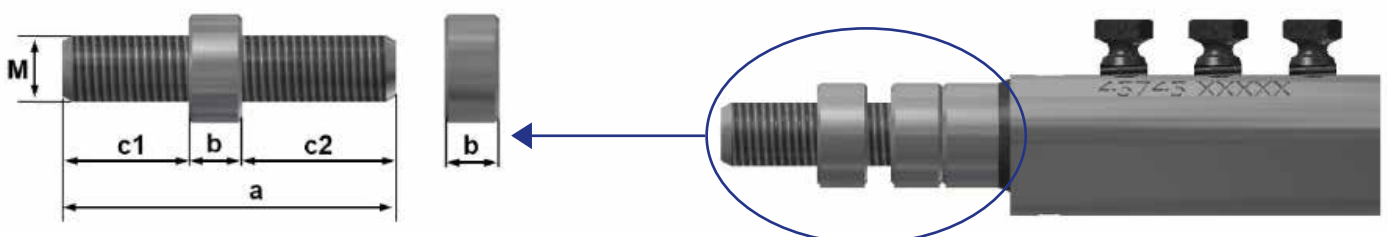

## Installation Option A

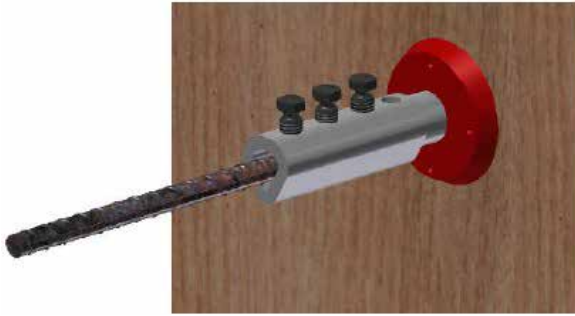

Attach the fixing plate to the shuttering system and screw the ALC-SKF (female) onto this. The rebar can now be inserted into this ensuring it reaches the stop pin. Once the bar is correctly inserted the lock shear bolts can be hand tight-ened.

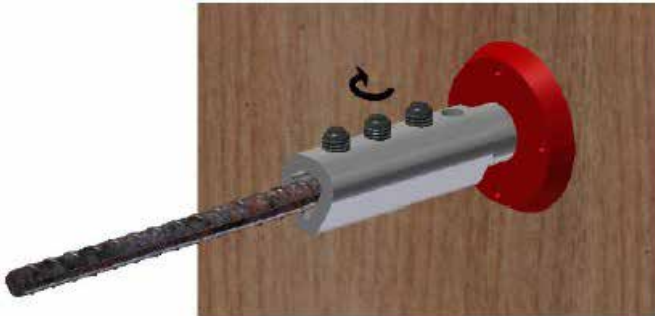

After confirming that the coupler is correctly aligned use the impact wrench (see page 13) to tighten the lock shear bolts, the bolts should be tightened in order working from the central stop pin towards the outside edge of the coupler. When each bolt reaches the correct torque setting the head of the lock shear bolt will shear off. The concrete can now be poured.

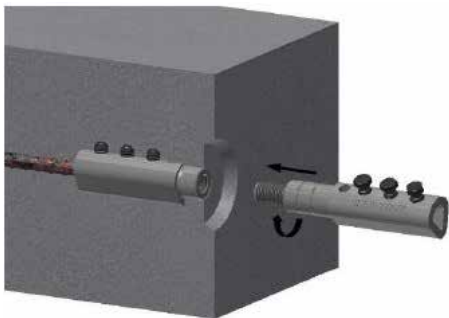

Once the concrete has cured sufficiently and the shuttering system has been removed the fixing plate is removed exposing the internally threaded section of the female coupler. The ALC-SKM (male) can be threaded in until the lock shear bolts come into a satisfactory alignment to allow access with the impact wrench.

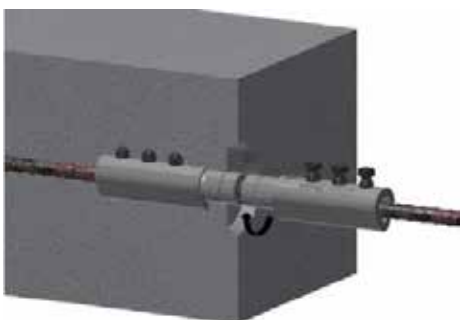

The locking rings should now be tightened using the calibrated torque wrench (see page 13) against both the female and male section of the coupler. The continuity steel can now be inserted into the coupler and the lock shear bolts can be tightened by hand.

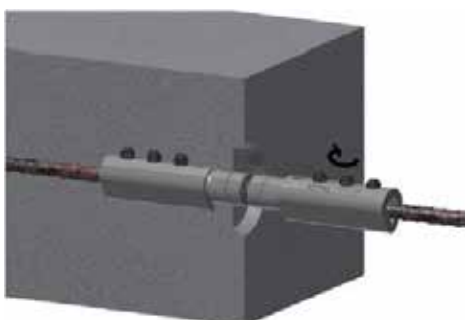

After confirming that the coupler is correctly aligned use the impact wrench (see page 13) to tighten the lock shear bolts, the bolts should be tightened in order working from the concrete face towards the outside edge of the coupler. When each bolt reaches the correct torque setting the head of the lock shear bolt will shear off. Complete this process for all couplers at the joint.

## Installation Option B

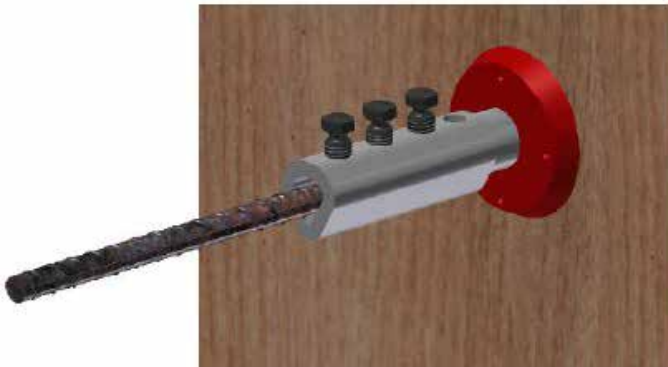

Attach the fixing plate to the shuttering system and screw the ALC-SKF (female) onto this. The rebar can now be inserted into this ensuring it reaches the stop pin. Once the bar is correctly inserted the lock shear bolts can be hand tightened.

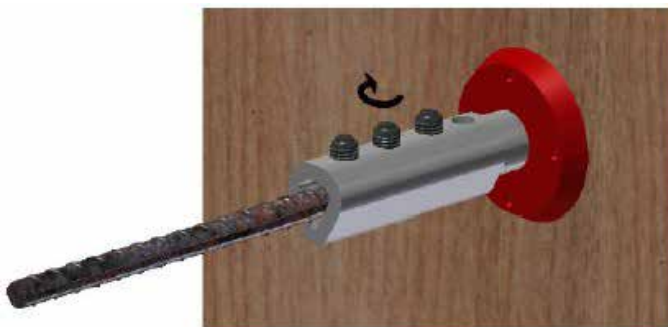

After confirming that the coupler is correctly aligned use the impact wrench (see page 13) to tighten the lock shear bolts, the bolts should be tightened in order working from the central stop pin towards the outside edge of the coupler. When each bolt reaches the correct torque setting the head of the lock shear bolt will shear off. The concrete can now be poured.

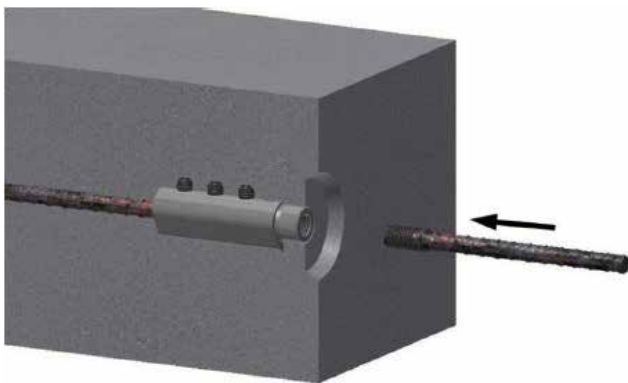

Once the concrete has cured sufficiently and the shuttering system has been removed the fixing plate is removed exposing the internally threaded section of the female coupler. The male TSE threaded coupler is threaded in until hand tight.

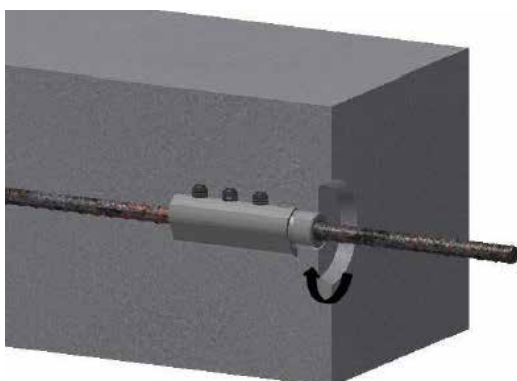

The male TSE should now be tightened using the calibrated torque wrench (see page 13).

# Repairing Damaged or Corroded Reinforcement

To carry out repairs to corroded or damaged reinforcement steel the following processes should be carried out.

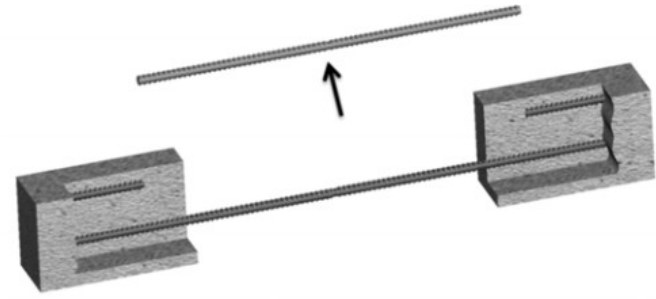

Firstly remove the rejected section of rebar, ensuring that a length of suitable concrete free reinforcement steel is left exposed at each side of the cut to accommodate at least the length of the corresponding Alligator Coupler of the equivalent bar diameter. The replacement length of reinforcement steel should be cut to a length 10mm less than the resultant gap in the reinforcement steel to allow easy installation.

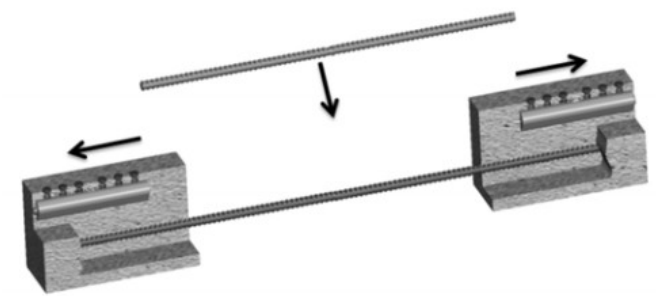

An Alligator coupler should be slipped over the bar at each side of the cut. It will be necessary to drive out the central stop pin on each coupler with a hammer and steel punch. This will turn the coupler into a slip coupler that will completely slide over the bar.

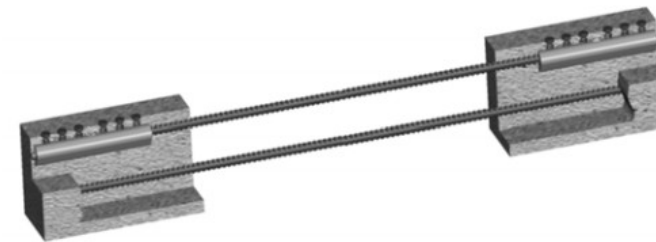

The replacement bar can be placed in the open gap and the couplers can be slid over both ends of the replacement bar, ensuring that the couplers are both equally placed over existing bar and the replacement bar. The lock shear bolts should be tightened by hand and the position of the coupler should be checked to ensure access with the impact wrench is possible.

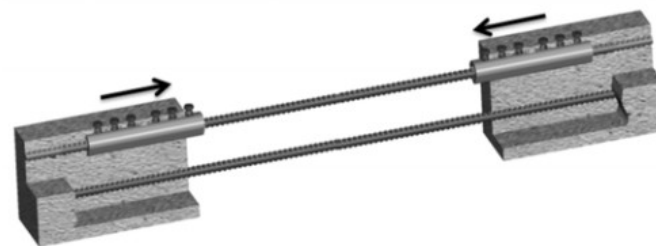

The lock shear bolts should be tightened with the impact wrench, it is advisable to tighten the lock shear bolts on the replacement bar first working from the internal edges first and tightening the lock shear bolts in order. If for some reason something is positioned incorrectly the replacement bar can be removed by cutting it rather than exposing more of the original reinforcement to cut the couplers off.

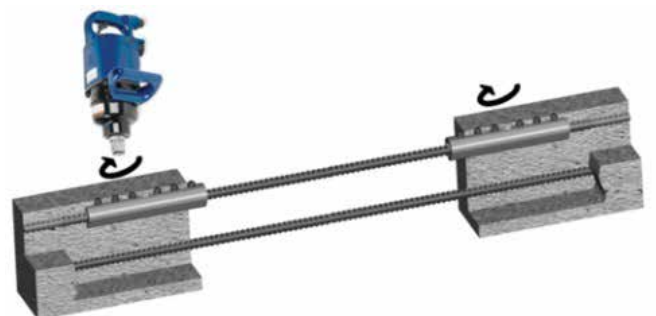

Finally tighten the lock shear bolts in contact with the original steel with the impact wrench ensuring all the heads shear off the bolts. Ensure adequate cover or protection measures are applied to the repair to prevent further corrosion.



## Tools for use with Alligator Coupler Range

To adequately tighten the lock shear bolts a suitable power tool with a torque capability twice that of the recommended torque requirements of the Alligator should be used. Euro Accessories offers the following tools for this process:

### PTWMAK

Power requirement: 110 V  
1000Nm of torque.  
1" square drive.

### PTWSNAP

Power requirement: Compressed air source.  
813-1898 Nm of torque.  
1" square drive.

### Electric Impact Wrench

Product Code	Description
PTWMAK	Electric Impact Wrench
PTWSNAP	Pneumatic Mounting Kit

Available to purchase or hire



The Electric Impact Wrench easily achieves the correct torque setting to effectively fix the ALC Couplers in place.



ALC Pneumatic Mounting Kit SNAP on tools.

## Calibrated Torque Wrench for use with the TSE Reinforcement Coupler

The calibrated torque wrench is specially designed for the correct installation of the Terwa couplers on site. All Terwa wrenches are delivered together with a calibration report and instructions for use. The torque values are marked on the wrench for all diameters of rebar.



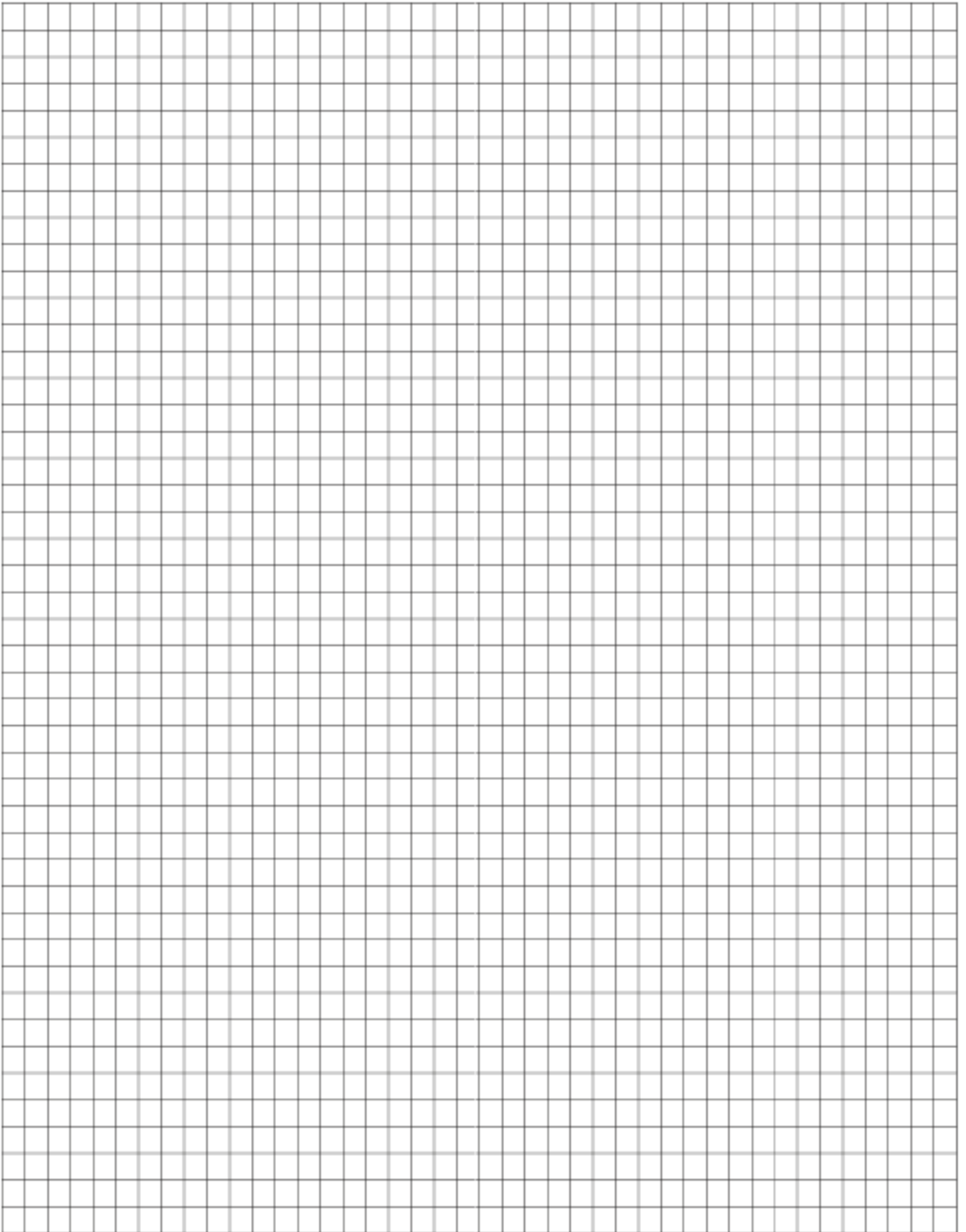

Product Code	Description
PSAWR	Wrench



#### Bluebay West & Wales

Unit 51, Portmanmoor Road Industrial,  
Estate, Ocean Park, Cardiff, CF24 5HB

 02920 495555

 02920 491700

 [cardiff@bluebaybp.co.uk](mailto:cardiff@bluebaybp.co.uk)

#### Bluebay London & S.E.

Unit 3, Stadium Ind Est, Cradock Road,  
Luton, Bedfordshire, LU4 0JF

 01582 594007

 01582 594009

 [london@bluebaybp.co.uk](mailto:london@bluebaybp.co.uk)

#### Bluebay Thames Valley

Unit 26A, Ganton Way, Techno Trading  
Estate, Swindon, Wilts, SN2 8EZ

 01793 512299

 01793 535888

 [swindon@bluebaybp.co.uk](mailto:swindon@bluebaybp.co.uk)

#### Bluebay North & Scotland

Unit 16G, Follingsby Park, Gateshead,  
Tyne and Wear, NE10 8YF

 0191 416 6572

 0191 416 8614

 [gateshead@bluebaybp.co.uk](mailto:gateshead@bluebaybp.co.uk)

#### Bluebay North West & E. Midlands

Unit 2A & 2B, New Cut Lane Ind Est,  
Warrington, WA1 4AG

 01925 875588

 01925 819559

 [warrington@bluebaybp.co.uk](mailto:warrington@bluebaybp.co.uk)